

CHAPTER 5

REAR SUSPENSION

REAR SUSPENSION ASSEMBLY	5— 1
VEHICLE HEIGHT ADJUSTMENT (REAR)	5— 3
REAR SPRING & REAR COIL SPRING	5— 4

REAR SUSPENSION

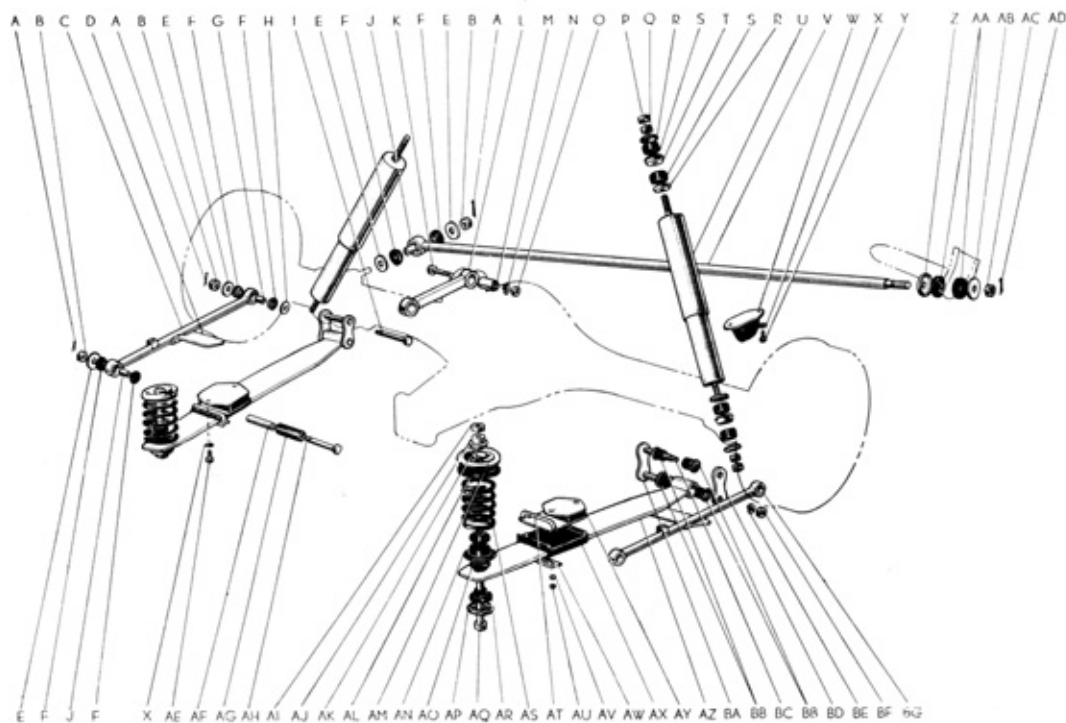

Fig. 5-1 Rear Suspension

- | | | | |
|---|---|----|--|
| A | Cotter Pin | W | Rear Cushion Rubber Complete |
| B | Nut | X | Spring Washer |
| C | Lower Control Rod Complete | Y | Bolt |
| D | Rear Spring Protector | Z | Lateral Rod Bushing Inner Retainer |
| E | Lower Control Rod Pivot Bolt Washer | AA | Lateral Rod Bushing |
| F | Lower Control Rod Bushing Rubber | AB | Lateral Rod Bushing Outer Retainer |
| G | Lower Control Rod Bushing Inner Long Pipe | AC | Nut |
| H | Lower Control Rod Pivot Bolt Inner Washer | AD | Cotter Pin |
| I | Lower Control Rod Rear Pivot Bolt | AE | Bolt |
| J | Lower Control Rod Bushing Inner Pipe | AF | Lower Control Rod Front Pivot Bolt Spacer |
| K | Bolt | AG | Lower Control Rod Front Pivot Bolt Spacer Rubber |
| L | Upper Control Arm | AH | Lower Control Rod Front Pivot Bolt |
| M | Upper Control Arm Bushing Complete | AI | Nut |
| N | Spring Washer | AJ | Tension Bolt Nut |
| O | Nut | AK | Tension Bolt Thrust Washer |
| P | Pawl Nut | AL | Rear Coil Spring Upper Insulator |
| Q | Nut | AM | Rear Coil Spring Seat |
| R | Shock Absorber Cushion Rubber Retainer | AN | Rear Coil Spring Lower Insulator |
| S | Shock Absorber Cushion Rubber | AO | Rear Spring Front Upper Rubber |
| T | Rear Shock Absorber Cushion Rubber Retainer | AP | Rear Spring Tension Bolt Washer |
| U | Rear Shock Absorber | AQ | Rear Spring Tension Bolt |
| V | Lateral Rod Complete | AR | Rear Spring Front Rubber |

AS Rear Coil Spring
 AT Rear Spring Center Clamp "U" Bolt
 AU Nut
 AV Nut
 AW Rear Spring Center Clamp Plate Complete
 AX Rear Spring Center Support Spacers
 AY Rear Spring Center Support Complete
 AZ Rear Spring

BA Rear Spring Shackle Plate
 BB Spring Eye Bushing
 BC Shackle Pin
 BD Rear Spring Shackle
 BE Spring Washer
 BF Nut
 BG Lower Control Rod Complete

*

*

*

REAR SUSPENSION ASSEMBLY

Removal

1. Remove rear seat, raise vehicle from floor, place it on stand and remove wheels.
2. Remove shock absorber and lateral rod.

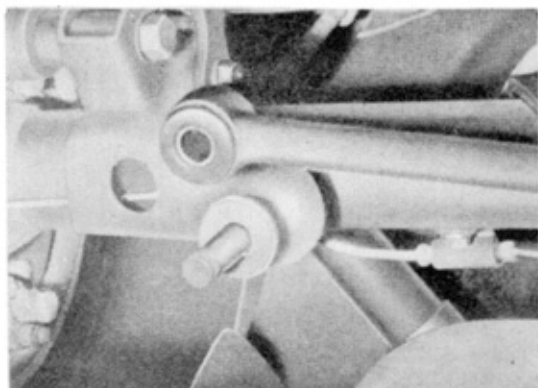

Fig. 5-2 Removing Lateral Rod

3. Remove lower control rod and upper control arm.



Fig. 5-3 Removing Upper Control Arm

4. Remove rear spring shackle.
5. Remove center support bolt and remove rear leaf spring.

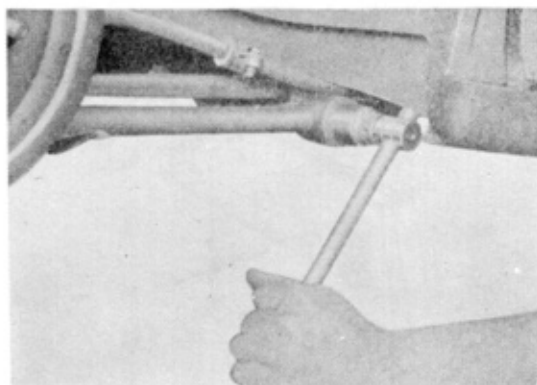

Fig. 5-4 Removing Lower Control Rod

Installation

1. Install rear leaf spring and install center support bolt.
 2. Insert lower control rod front pivot bolt and spacer.
 3. Install rear spring shackle.
 4. Install rear coil spring and install rear seat.
- Caution:** Tension bolt nut should be tightened so that the lock nut may be flush with the upper end of the tension bolt.
5. Install upper control arm.
 6. Install lower control rod.

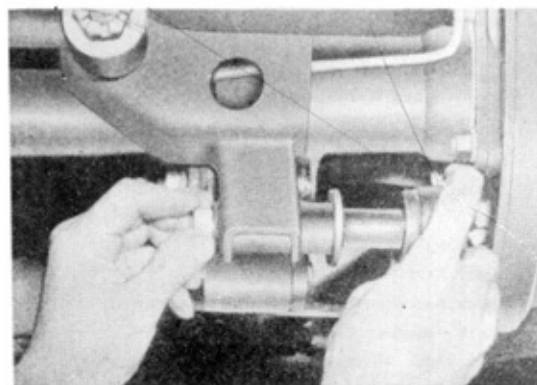

Fig. 5-5 Installing Lower Control Rod

7. Install lateral rod.
Caution: After tightening nut attaching lateral rod to body, lock with cotter pin.
8. Install shock absorber.
9. Install wheels and lower vehicle to floor.
10. Install rear seat.
11. Under standard load, loosen upper control arm shaft nut and lower control rod shaft nut until bushing and bushing rubbers have no more twists, then tighten again

to specified torque and install cotter pin.

Torque Spec.

- Upper Control Arm Shaft Nut
 9~10 m-kg (65~73 ft-lb)
- Lower Control Rod Shaft Nut
 18~20 m-kg (130~145 ft-lb)
- Lateral Rod Shaft Nut
 11~12 m-kg (80~87 ft-lb)

12. Adjust vehicle height.

VEHICLE HEIGHT ADJUSTMENT (REAR)

Measure the distance from the floor to the center of the lower control rod front pivot bolt.

Standard Vehicle Height
 under the standard load
 196 mm (7⁵/₈"")
 under the no load
 230 mm (9"")

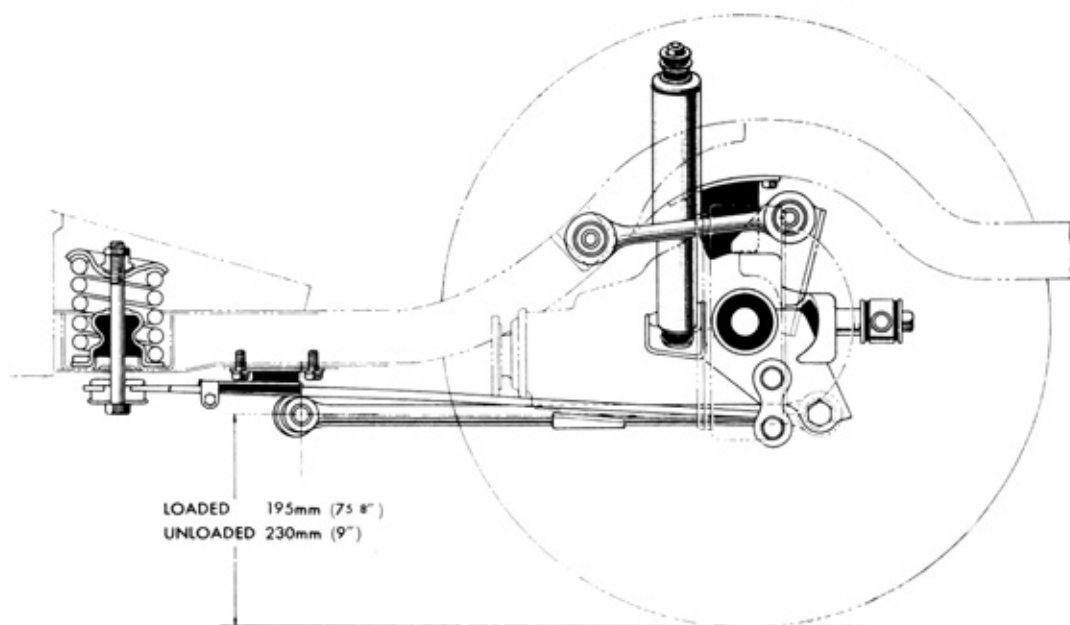

Fig. 5-6 Vehicle Height Adjustment

Caution:

- a. Inflation pressure of all tires must be 1.5 kg/cm² (22 lb/in²)
- b. When measuring the vehicle height, place the vehicle on a level floor, bounce and rock the car several times and allow it to settle to a normal height.

Vehicle height adjustment is made by the tension bolt nut of the rear coil spring.

- a. Tighten nut to raise vehicle height.
- b. Unloosen nut to lower vehicle height.

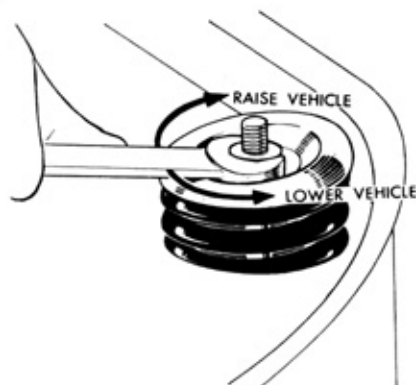

Fig. 5-7 Adjusting Rear Vehicle Height

REAR SPRING & REAR COIL SPRING

Removal

1. Remove rear seat, raise vehicle from floor, place on stand and remove wheels.
2. Disconnect front end of the lower control rod.
3. Remove rear spring shackle.

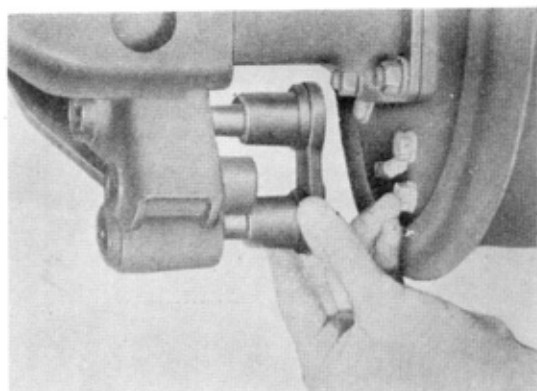

Fig. 5-8 Removing Rear Spring Shackle

4. Remove rear coil spring.

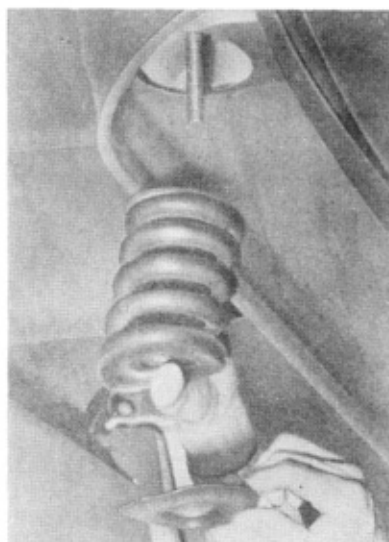

Fig. 5-9 Removing Rear Coil Spring

5. Remove center support bolt and remove rear spring.

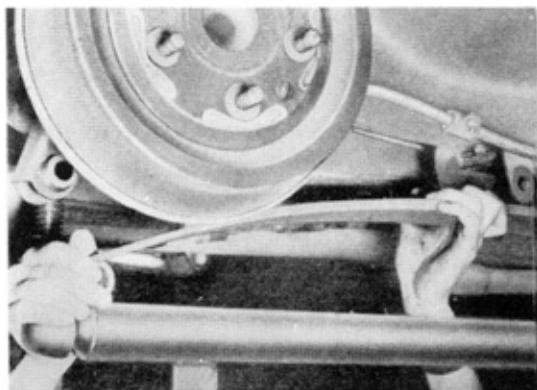

Fig. 5-10 Removing Rear Spring

Inspection

1. Replace rear spring, if it is worn or stretched out of shape.
2. Replace rear coil spring if it is worn, compressed or stretched out of shape.

Installation

1. Install rear spring and install center support bolt.
2. Insert lower control rod front pivot bolt and spacer.

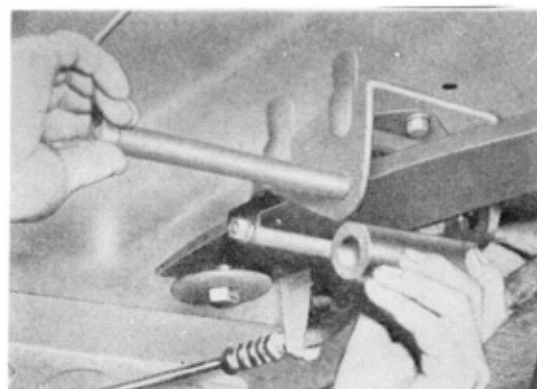

Fig. 5-11 Installing Pivot Bolt & Spacer

3. Install rear spring shackle.
4. Install rear coil spring and rear seat.
Caution: Tension bolt nut should be tightened so that the lock nut may be flush with the upper end of the tension bolt.
5. Install lower control rod to lower control rod front pivot bolt, and install nut.
6. Install wheels and lower vehicle to floor.

7. Install rear seat.
8. Under standard load, loosen lower control rod shaft nuts until bushings have no more twist, tighten again to specified torque and install cotter pin.

Torque Spec. 18~20 m·kg (130~145 ft·lb)

9. Adjust vehicle height.
(See page 5-3 "VEHICLE HEIGHT ADJUSTMENT").

LOWER CONTROL ROD, UPPER CONTROL ARM & LATERAL ROD

Inspection

Replace lower control rod, upper control arm or lateral rod, if they are bent or cracked.